



SoundStar Series

Compact Siren & Speaker

FEDERAL SIGNAL VAMA, S.A.

C/Dr.Ferrán,7(08339)VILASSAR DE DALT - SPAIN

Tel: (34) 93.741.79.00

Telefax: (34) 93.753.03.62

WEB: www.fedsigvama.com



SCS1000 Compact Siren (30W)

(D) MONTAGE-UND FUNKTIONSBESCHREIBUNG

(E) INSTRUCCIONES DE INSTALACION Y FUNCIONAMIENTO

(F) INSTRUCTIONS POUR INSTALLATION ET FONCTIONNEMENT

(GB) INSTALLATION AND OPERATING INSTRUCTIONS

(I) ISTRUZIONI D'INSTALLAZIONE E FUNZIONAMENTO

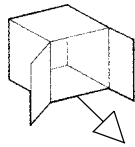
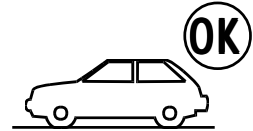
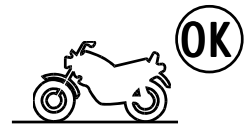

SCS1000	ref. 2020200
SCS1000-FG	ref. 2020193
SCS1000N	ref. 2020207
SCS1000N-FG	ref. 2020217
SCS1000 Día/Noche	ref. 2020227
SCS1000	ref. 2020200-BL
SCS1000-FG	ref. 2020193-BL
SCS1000N	ref. 2020207-BL
SCS1000N-FG	ref. 2020217-BL
SCS1000 Día/Noche	ref. 2020227-BL

(D) BESTANDTEILE

(E) CONTENIDO

(F) CONTENU

(GB) CONTENTS

(I) CONTENUTO

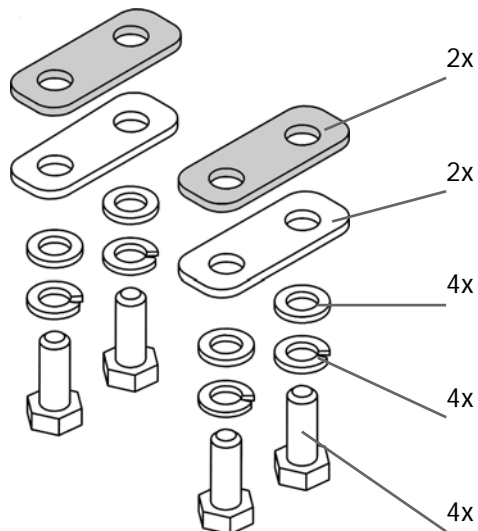
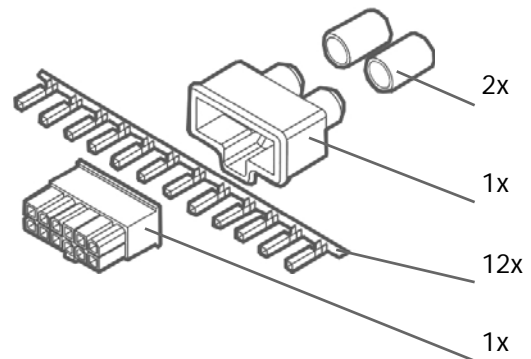
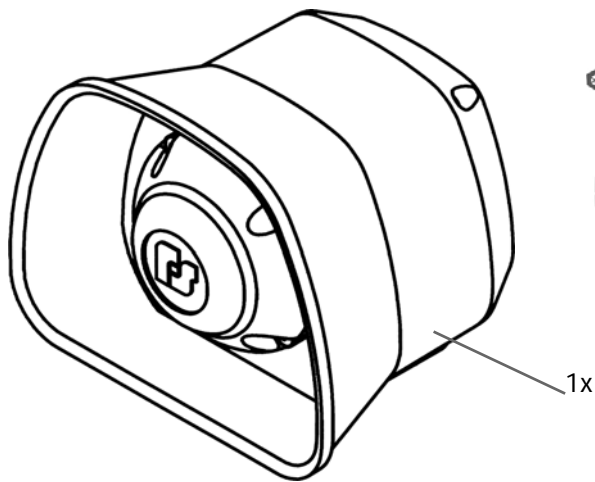

1x
ref. 91471139

ALS1000 Compact Speaker(30W)

D MONTAGE-UND FUNKTIONSBESCHREIBUNG

E INSTRUCCIONES DE INSTALACION Y FUNCIONAMIENTO

F INSTRUCTIONS POUR INSTALLATION ET FONCTIONNEMENT

GB INSTALLATION AND OPERATING INSTRUCTIONS

I ISTRUZIONI D'INSTALAZIONE E FUNZIONAMENTO

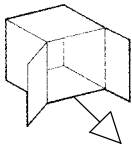
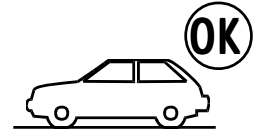
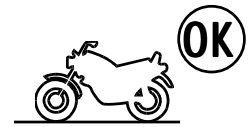

ALS1000 ref.2021049
 ALS1000N ref.2021050
 ALS1000 ref.2021049-BL
 ALS1000N ref.2021050-BL

D BESTANDTEILE

E CONTENIDO

F CONTENU

GB CONTENTS

I CONTENUTO

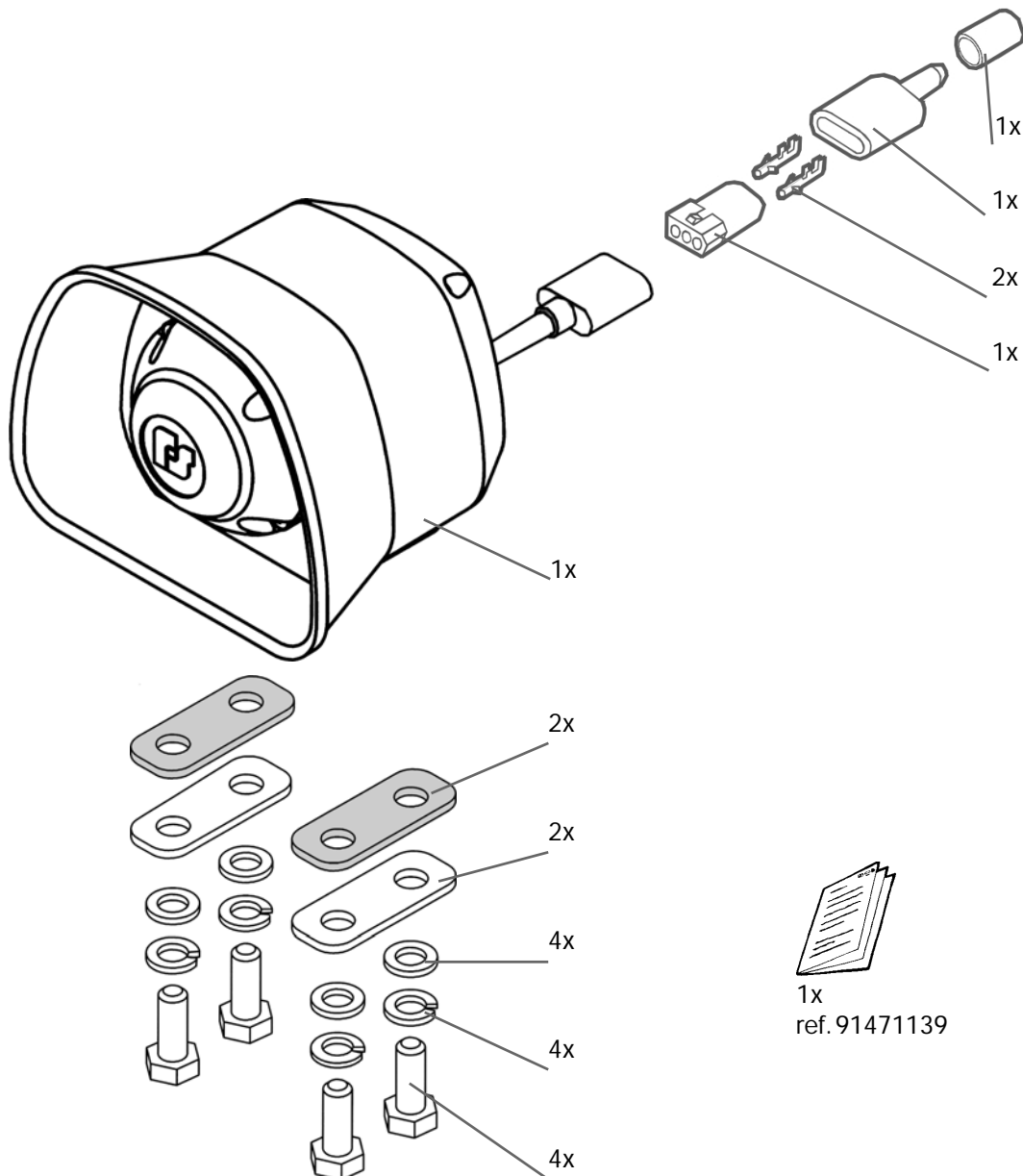

D SPECIFIKATION



F CARACTERISTIQUES

I SPECIFICAZIONI

E ESPECIFICACIONES

GB ESPECIFICATIONS

SCS1000 Siren

V:	12 V DC (11-15,5 Vcc)
W:	30+30 W
t:	-30° C / +50° C
I:	3 A max. () 6 A max. ( )
V out:	23 V pp

ALS1000 Speaker

W:	30 W
t:	-30° C / +50° C
I:	3 A max. ()
V out:	23 V pp

D SICHERHEITSHINWEISE FÜR INSTALLATEURE

Menschliches Leben hängt von der sicheren Installation unserer Produkte ab. Deshalb ist es sehr wichtig, sämtliche Anweisungen zu diesem Produkt und zu den einzelnen Teilen aufmerksam zu lesen und zu befolgen. Im folgenden werden einige Sicherheitsvorschriften und andere wichtige Massnahmen beschrieben, die unbedingt beachtet werden müssen.

- Um die Einheit richtig einzubauen, ist es wichtig, die einzelnen Vorgänge und die elektrischen Systeme zu verstehen und den Installationsprozess der Sicherheitsanzeige genau zu kennen.
- Wenn Sie Löcher in die Fahrzeugstruktur bohren, versichern Sie sich, dass an keiner der beiden Oberflächenseiten etwas beschädigt werden kann. Die Flächen um die Löcher müssen vollkommen glatt sein. Um Kurzschlüsse zu verhindern, ist es empfehlenswert eine Unterlegscheibe aus Gummi an denjenigen Löchern anzubringen, durch die Kabel geführt werden.
- Ein Lichtsystem / tonanlage ist eine Hochspannungsvorrichtung. Damit sie perfekt funktioniert, muss ein separater Erdanschluss vorgesehen werden, und zwar am besten an der negativen Klemme der Batterie, aber mindestens an einem Metallteil oder anderem festen Teil der Karosserie, damit bei Benutzung der Einheit die Erdung sichergestellt ist.
- Bei den mit Stroboskoplichtern ausgestatteten Modellen besteht während und nach dem Betrieb Hochspannung. Versichern Sie sich, dass der Strom abgestellt ist, und warten Sie mindestens zehn Minuten bevor Sie die Abdeckung entfernen.
- Bringen Sie die Steuerung der Einheit so an, dass sich das FAHRZEUG und die STEUERUNG während der Fahrt immer sicher bedienen lassen.
- Sie sollten die Einheit regelmässig überprüfen, damit ihr einwandfreier Betrieb und ihr fester Sitz im Fahrzeug zu jeder Zeit sichergestellt sind.
- Bewahren Sie diese Anweisungen an einem sicheren Ort auf, und nehmen Sie sie wieder zur Hand, wenn Sie Wartungsarbeiten vornehmen oder die Lampe erneut einbauen.

Die Nichteinhaltung der Sicherheitsvorschriften kann Schäden an den Gegenständen und schwere Personenschäden hervorrufen und sogar Lebensgefahr für Sie oder andere darstellen.

E MENSAJE DE SEGURIDAD PARA EL INSTALADOR

La vida de las personas depende de una instalación adecuada y segura de nuestros productos. Es importante que Vd. lea, comprenda y siga atentamente todas las instrucciones que se acompañan a este producto y sus productos complementarios. Además, a continuación le relacionamos una serie de instrucciones de seguridad y precauciones importantes que Vd. debería observar:

- Para instalar adecuadamente este equipo: Vd. debe tener un buen conocimiento de electricidad del automóvil, además de formación en la instalación y utilización de equipos de Seguridad.
- Cuando proceda a taladrar la estructura o chapa del vehículo, asegúrese de que ambos lados de la superficie se encuentran libres de cualquier elemento que pudiera resultar dañado. Limpie los agujeros realizados de cualquier resto de material que haya podido quedar. Para prevenir cortocircuitos, se aconseja usar pasacables aislantes en los agujeros por donde pase el cable.
- Luz / sonido es un dispositivo por el que circula una intensidad alta de corriente. Para que pueda funcionar adecuadamente, debe instalarse una conexión separada a masa. En el caso de que sea posible, aconsejamos conectarlo al terminal negativo de la batería. Como mínimo debería fijarse a un elemento metálico sólido o a una parte del chasis, que proporcionen un paso a masa efectivo cuando el equipo sea utilizado.
- Se producen voltajes altos dentro de los modelos equipados con luces estroboscópicas durante y después de su funcionamiento. Asegúrese de que la fuente de alimentación se encuentra desconectada y espere al menos DIEZ MINUTOS antes de desmontar la lente de la luz.
- Disponga los equipos de modo que el VEHÍCULO y los CONTROLES puedan ser manejados con seguridad bajo cualquier condición de conducción.
- Vd. debería revisar frecuentemente los equipos para asegurar que funcionan adecuadamente y que se encuentran convenientemente fijados al vehículo.
- Conserve estas instrucciones en un lugar seguro y remítase a ellas cuando efectúe operaciones de mantenimiento o reinstale el producto.

El no cumplimiento de estas normas de precaución puede dar como resultado daños a la propiedad, lesiones graves o muerte tanto para Vd. como para otras personas.

F MESSAGE AUX INSTALLATEURS CONCERNANT LA SÉCURITÉ

La vie de personnes dépend de la prudente installation de nos produits. Il est indispensable de lire, de comprendre et de suivre toutes les instructions remises avec ce produit et les produits complémentaires inclus. Nous vous indiquons une liste supplémentaire, ci-dessous, de quelques instructions importantes concernant la sécurité ainsi que des précautions que vous devrez suivre:

- Pour installer correctement ce produit: vous devez être familiarisé avec les systèmes et les procédures électriques automobiles, et avoir des compétences en ce qui concerne l'installation et l'utilisation d'équipements munis de système de sécurité.
- Lorsque vous percez la structure du véhicule, assurez-vous que les deux surfaces sont vierges de toute chose pouvant être endommagée. Pour éviter les court-circuits électriques, baguez tous les trous percés qui seront utilisés pour faire passer les câbles.
- Tout système lumineux / sonore implique un fort courant électrique. Pour qu'il fonctionne correctement, il est nécessaire de créer une prise de terre supplémentaire. Si c'est possible, il devra être relié à la borne négative de la batterie. Il pourra, à la limite, être rattaché à un corps métallique solide ou à un élément du châssis qui fournira un passage à terre efficace aussi longtemps que ce produit devra être utilisé.
- On trouve de hauts voltages à l'intérieur des modèles au Xénon pendant et après l'opération. Assurez-vous que le courant est coupé et attendez au moins dix minutes avant d'ôter le dôme.
- Disposez les contrôles de systèmes lumineux de manière à ce que le VÉHICULE et les CONTRÔLES puissent être utilisés en toute sécurité dans toutes les conditions de conduite possibles.
- Vous devrez fréquemment vérifier l'équipement pour vous assurer qu'il fonctionne correctement et qu'il est proprement connecté au véhicule.
- Gardez ces instructions dans un endroit sûr et n'hésitez pas à vous y reporter lors de l'entretien et/ou de la réinstallation du produit. Le non respect de ces précautions et instructions peut entraîner l'endommagement de la propriété et de graves blessures, ou même la mort, pour vous ou d'autres personnes.

GB SAFETY MESSAGE TO INSTALLERS

People's lives depend on your safe installation of our products. It is important to read, understand and follow all instructions shipped with this product and the related add-on products. In addition, listed below are some other important safety instructions and precautions you should follow:

- To properly install this product: you must have a good understanding of automotive electrical procedures and systems, along with proficiency in the installation and use of safety warning equipment.
 - When drilling into a vehicle structure, be sure that both sides of the surface are clear of anything that could be damaged. Remove all burrs from drilled holes. To prevent electrical shorts, grommet all drilled holes through which wiring passes.
 - A light / sound system is a high current device. In order for it to function properly, a separate ground connection must be made. If practical, it should be connected to the negative battery terminal. At a minimum, it may be attached to a solid metal body or chassis part that will provide an effective ground path as long as the equipment is to be used.
 - High voltages are present inside the strobe light equipped models during and after operation. Ensure that power is disconnected and wait at least ten minutes before removing the dome.
 - Locate the equipment so the VEHICLE and CONTROLS can be operated safely under all driving conditions.
 - You should frequently inspect the equipment to ensure that it is operating properly and that it is securely attached to the vehicle.
 - File these instructions in a safe place and refer to them when maintaining and reinstalling the product.
- Failure to follow all safety precautions and instructions may result in property damage, serious injury, or death to you or to others.

I INFORMAZIONI DI SICUREZZA PER L'INSTALLATORE

La vita delle persone dipende da una corretta installazione dei nostri prodotti. È importante leggere, capire ed eseguire attentamente le istruzioni che accompagnano questo prodotto ed i suoi elementi complementari. Vi elenchiamo alcune importanti istruzioni di sicurezza e precauzioni da seguire:

- Per installare correttamente questi prodotti, è necessario avere una buona conoscenza della parte elettrica dell'automobile ed avere padronanza dell'installazione e dell'uso di apparecchiature di sicurezza.
- Quando si procede alla foratura della struttura del veicolo, assicurarsi che sui due lati della superficie non ci sia nulla che possa essere danneggiato. Eliminare qualsiasi residuo di materiale dai fori realizzati. Per evitare cortocircuiti, si consiglia di applicare del materiale isolante nei fori dove devono passare i cavi.
- I sistemi luminosi / sonori sono apparecchiature in cui circola corrente ad alta tensione. Affinchè funzionino correttamente, si deve installare una connessione a massa separata. Nel caso sia possibile, consigliamo di collegarla al terminale negativo della batteria. Come minimo dovrebbe essere fissato ad un elemento metallico fisso oppure al telaio del veicolo al fine di realizzare una efficace massa quando si usano i sistemi luminosi / sonori.
- All'interno dei modelli equipaggiati con luci stroboscopiche è presente una elevata tensione elettrica durante e dopo il funzionamento. Assicurarsi che l'alimentatore sia staccato ed attendere almeno 10 minuti prima di smontare la cupola della luce.
- Porre i comandi delle luci ausiliarie o della sirena in modo tale che sia il veicolo che i comandi possano essere utilizzati in maniera sicura in qualsiasi situazione di guida.
- Si dovrebbero verificare spesso i sistemi (luci, sirena) per assicurarsi che funzionino adeguatamente e che siano fissati in modo sicuro al veicolo.
- Vi preghiamo di conservare queste istruzioni in un luogo sicuro e di consultarle quando si effettua la manutenzione oppure quando si reinstalla il prodotto.

Nel caso non venissero seguite queste istruzioni, si possono provocare danni alla proprietà, lesioni gravi o morte propria o degli altri.

SCS1000 ref. 2020200

SCS1000 ref. 2020200-BL

- (D)** FUNKTIONSBESCHREIBUNG
- (E)** USO DE LA SIRENA
- (F)** FONCTIONNEMENT DE LA SIRENE
- (GB)** OPERATING INSTRUCTIONS
- (I)** USO DELLA SIRENA

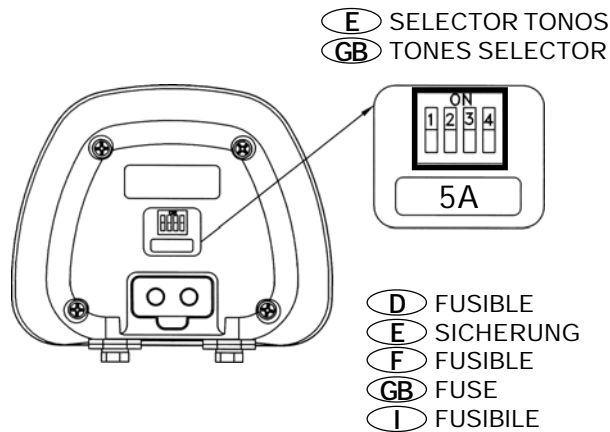

DESCRIPCIÓN DESCRIPTION	SELECTOR TONOS TONES SELECTOR	FRECUENCIA FREQUENCY	TONOS TONES								
STANDARD	<table border="1"><tr><td></td><td></td><td></td><td></td></tr><tr><td>1</td><td>2</td><td>3</td><td>4</td></tr></table>					1	2	3	4	600-1200 Hz 600-1200 Hz 450-600 Hz	WAIL 12 c/m. YELP 180 c/m. TWO TONES 33 c/m.
1	2	3	4								
STANDARD/AIRHORN	<table border="1"><tr><td>1</td><td></td><td></td><td></td></tr><tr><td></td><td>2</td><td>3</td><td>4</td></tr></table>	1					2	3	4	600-1200 Hz 600-1200 Hz 450-600 Hz	WAIL 12 c/m. YELP 180 c/m. TWO TONES 33 c/m. AIRHORN
1											
	2	3	4								
WAIL/YELP/AIRHORN	<table border="1"><tr><td></td><td>2</td><td></td><td></td></tr><tr><td>1</td><td></td><td>3</td><td>4</td></tr></table>		2			1		3	4	600-1200 Hz 600-1200 Hz	WAIL 12 c/m. YELP 180 c/m. AIRHORN
	2										
1		3	4								
IBEROAMÉRICA/ENGLAND	<table border="1"><tr><td>1</td><td>2</td><td></td><td></td></tr><tr><td></td><td></td><td>3</td><td>4</td></tr></table>	1	2					3	4	600-1200 Hz 600-1200 Hz	WAIL 12 c/m. YELP 180 c/m.
1	2										
		3	4								
DENMARK (DINAMARCA)	<table border="1"><tr><td></td><td></td><td>3</td><td></td></tr><tr><td>1</td><td>2</td><td></td><td>4</td></tr></table>			3		1	2		4	600-1200 Hz 450-600 Hz	YELP 180 c/m. TWO TONES 60 c/m.
		3									
1	2		4								
SWEDEN (SUECIA)	<table border="1"><tr><td>1</td><td></td><td>3</td><td></td></tr><tr><td></td><td>2</td><td></td><td>4</td></tr></table>	1		3			2		4	530-700 Hz 600-1200 Hz	TWO TONES 30 c/m. YELP 180 c/m.
1		3									
	2		4								
BITONE	<table border="1"><tr><td></td><td>2</td><td>3</td><td></td></tr><tr><td>1</td><td></td><td></td><td>4</td></tr></table>		2	3		1			4	450-600 Hz	TWO TONES 33 c/m.
	2	3									
1			4								
ÖSTERREICH POLIZEI (AUSTRIA POLICIA)	<table border="1"><tr><td>1</td><td>2</td><td>3</td><td></td></tr><tr><td></td><td></td><td></td><td>4</td></tr></table>	1	2	3					4	430-575 Hz	TWO TONES 25 c/m.
1	2	3									
			4								
ÖSTERREICH KRANKENWAGEN (AUSTRIA AMBULANCIAS)	<table border="1"><tr><td></td><td></td><td></td><td>4</td></tr><tr><td>1</td><td>2</td><td>3</td><td></td></tr></table>				4	1	2	3		530-400 Hz	TWO TONES 40 c/m.
			4								
1	2	3									
CANARIAS	<table border="1"><tr><td>1</td><td></td><td></td><td>4</td></tr><tr><td></td><td>2</td><td>3</td><td></td></tr></table>	1			4		2	3		420-516 Hz	DOS TONOS 98 c/m.
1			4								
	2	3									
NETHERLANDS POLICE (HOLANDA POLICÍA)	<table border="1"><tr><td></td><td>2</td><td></td><td>4</td></tr><tr><td>1</td><td></td><td>3</td><td></td></tr></table>		2		4	1		3		375-500 Hz 375-500 Hz	TWO TONES 66 c/m. TWO TONES 33 c/m.
	2		4								
1		3									
NETHERLANDS AMBULANCE (HOLANDA AMBULANCIA)	<table border="1"><tr><td>1</td><td>2</td><td></td><td>4</td></tr><tr><td></td><td></td><td>3</td><td></td></tr></table>	1	2		4			3		450-800-641 Hz	TWO TONES 16 c/m.
1	2		4								
		3									

SCS1000-FG ref. 2020193

SCS1000-FG ref. 2020193-BL

- (D)** FUNKTIONSBESCHREIBUNG
- (E)** USO DE LA SIRENA
- (F)** FONCTIONNEMENT DE LA SIRENE
- (GB)** OPERATING INSTRUCTIONS
- (I)** USO DELLA SIRENA

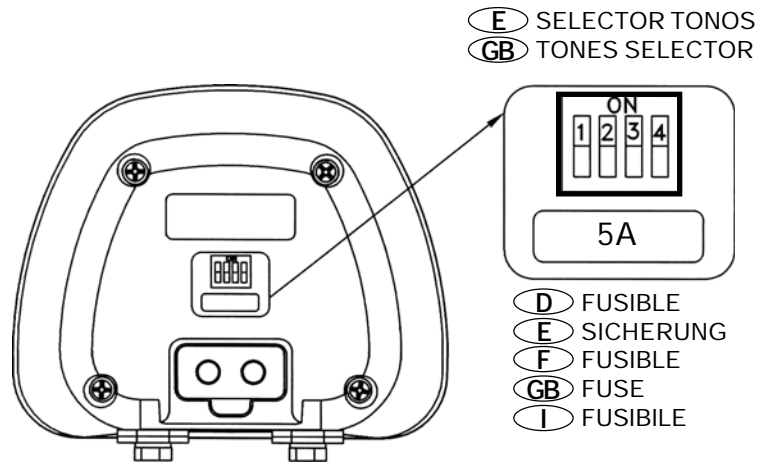

DESCRIPCIÓN DESCRIPTION	SELECTOR TONOS TONES SELECTOR	FRECUENCIA FREQUENCY	TONOS TONES	ALTA/BAJA INTENSIDAD HIGH/LOW INTENSITY								
GUARDIA URBANA BCN	<table border="1"><tr><td></td><td></td><td></td><td></td></tr><tr><td>1</td><td>2</td><td>3</td><td>4</td></tr></table>					1	2	3	4	550-750 Hz	TWO TONES 68 c/m.	-
1	2	3	4									
DEUTSCHLAND (ALEMANIA)	<table border="1"><tr><td></td><td>2</td><td>3</td><td></td></tr><tr><td>1</td><td></td><td></td><td>4</td></tr></table>		2	3		1			4	432-576 Hz 362-483 Hz	DOPPELTON 40 c/m. DOPPELTON 40 c/m.	STADT / LAND
	2	3										
1			4									
FRANCE AMBULANCE (FRANCIA AMBULANCIA)	<table border="1"><tr><td>1</td><td></td><td>3</td><td></td></tr><tr><td></td><td>2</td><td></td><td>4</td></tr></table>	1		3			2		4	420-516-420 Hz	DEUX TONES 30 c/m.	-
1		3										
	2		4									
FRANCE GENDARMERIE (FRANCIA GENDARMERIA)	<table border="1"><tr><td>1</td><td></td><td></td><td></td></tr><tr><td></td><td>2</td><td>3</td><td>4</td></tr></table>	1					2	3	4	435-735 Hz	DEUX TONES 55 c/m	-
1												
	2	3	4									
FRANCE POLICE (FRANCIA POLICIA)	<table border="1"><tr><td></td><td></td><td>3</td><td></td></tr><tr><td>1</td><td>2</td><td></td><td>4</td></tr></table>			3		1	2		4	435-580 Hz	DEUX TONES 55 c/m.	JOUR / NUIT
		3										
1	2		4									
FRANCE POMPIERS (FRANCIA BOMBEROS)	<table border="1"><tr><td></td><td>2</td><td></td><td></td></tr><tr><td>1</td><td></td><td>3</td><td>4</td></tr></table>		2			1		3	4	435-488 Hz	DEUX TONES 27c/m.	-
	2											
1		3	4									
FRANCE UMH (FRANCIA UMH)	<table border="1"><tr><td>1</td><td>2</td><td></td><td></td></tr><tr><td></td><td></td><td>3</td><td>4</td></tr></table>	1	2					3	4	435-651 Hz	DEUX TONES 55 c/m.	JOUR / NUIT
1	2											
		3	4									
SWITZERLAND (SUIZA)	<table border="1"><tr><td>1</td><td>2</td><td>3</td><td></td></tr><tr><td></td><td></td><td></td><td>4</td></tr></table>	1	2	3					4	450-600 Hz	TWO TONES 40 c/m.	-
1	2	3										
			4									

SCS1000N ref. 2020207

SCS1000N ref. 2020207-BL

- (D)** FUNKTIONSBESCHREIBUNG
- (E)** USO DE LA SIRENA
- (F)** FONCTIONNEMENT DE LA SIRENE
- (GB)** OPERATING INSTRUCTIONS
- (I)** USO DELLA SIRENA

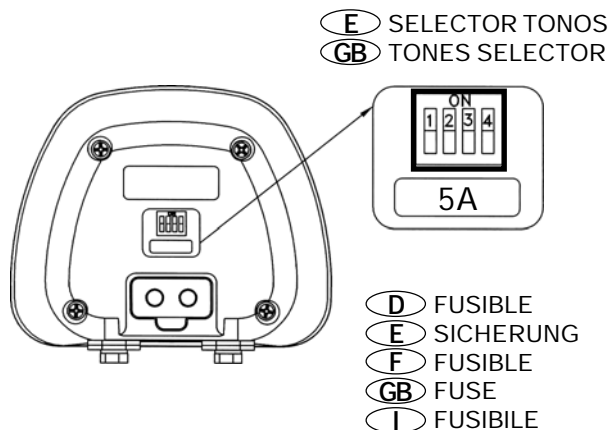

DESCRIPCIÓN DESCRIPTION	SELECTOR TONOS TONES SELECTOR	FRECUENCIA FREQUENCY	TONOS TONES								
ITALIA AMBULANZIA	<table border="1" style="display: inline-table;"><tr><td></td><td>2</td><td>3</td><td></td></tr><tr><td>1</td><td></td><td></td><td>4</td></tr></table>		2	3		1			4	392-660 Hz	TWO TONES 20 c/m.
	2	3									
1			4								
ITALIA AMBULANZIA 2	<table border="1" style="display: inline-table;"><tr><td>1</td><td>2</td><td>3</td><td></td></tr><tr><td></td><td></td><td></td><td>4</td></tr></table>	1	2	3					4	600-1200 Hz 600-1200 Hz 392-660 Hz	WAIL 12 c/m. YELP 180 c/m. TWO TONES 20 c/m.
1	2	3									
			4								
ITALIA POLIZIA	<table border="1" style="display: inline-table;"><tr><td>1</td><td></td><td>3</td><td></td></tr><tr><td></td><td>2</td><td></td><td>4</td></tr></table>	1		3			2		4	466-622 Hz	TWO TONES 40 c/m
1		3									
	2		4								
DEUTSCHLAND STADT (ALEMANIA CAMPO)	<table border="1" style="display: inline-table;"><tr><td></td><td></td><td></td><td>4</td></tr><tr><td>1</td><td>2</td><td>3</td><td></td></tr></table>				4	1	2	3		362-483 Hz (STADT)	TWO TONES 40 c/m.
			4								
1	2	3									
DEUTSCHLAND STADT/LAND (ALEMANIA CAMPO/CIUDAD)	<table border="1" style="display: inline-table;"><tr><td></td><td></td><td></td><td></td></tr><tr><td>1</td><td>2</td><td>3</td><td>4</td></tr></table>					1	2	3	4	362-483 Hz (STADT) 432-576 Hz (LAND)	TWO TONES 40 c/m. TWO TONES 40 c/m.
1	2	3	4								
NETHERLANDS POLICE (HOLANDA POLICIA)	<table border="1" style="display: inline-table;"><tr><td></td><td>2</td><td></td><td></td></tr><tr><td>1</td><td></td><td>3</td><td>4</td></tr></table>		2			1		3	4	375-500 Hz 375-500 Hz	TWO TONES 33 c/m. TWO TONES 66 c/m.
	2										
1		3	4								
STANDARD	<table border="1" style="display: inline-table;"><tr><td></td><td></td><td>3</td><td></td></tr><tr><td>1</td><td>2</td><td></td><td>4</td></tr></table>			3		1	2		4	600-1200 Hz 600-1200 Hz 450-600 Hz	WAIL 12 c/m. YELP 180 c/m. TWO TONES 33 c/m.
		3									
1	2		4								
STANDARD/AIRHORN	<table border="1" style="display: inline-table;"><tr><td>1</td><td>2</td><td></td><td></td></tr><tr><td></td><td></td><td>3</td><td>4</td></tr></table>	1	2					3	4	600-1200 Hz 600-1200 Hz 450-600 Hz	WAIL 12 c/m. YELP 180 c/m. TWO TONES 33 c/m. AIRHORN
1	2										
		3	4								

SCS1000N-FG ref. 2020217

SCS1000N-FG ref. 2020217-BL

- D** FUNKTIONSBESCHREIBUNG
- E** USO DE LA SIRENA
- F** FONCTIONNEMENT DE LA SIRENE
- GB** OPERATING INSTRUCTIONS
- I** USO DELLA SIRENA

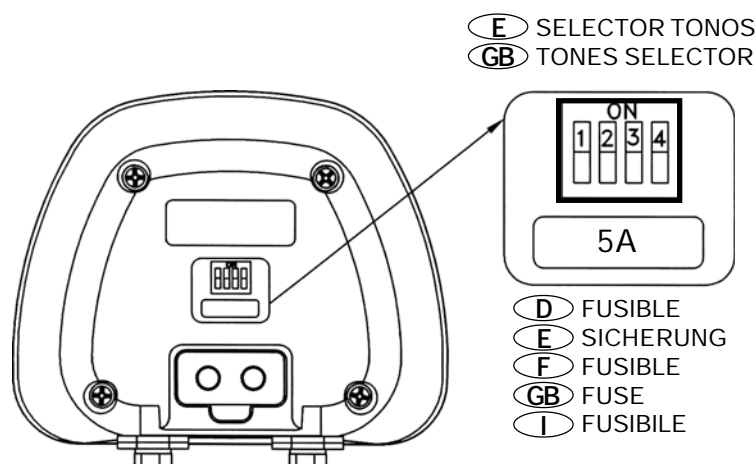

DESCRIPCIÓN <i>DESCRIPTION</i>	SELECTOR TONOS <i>TONES SELECTOR</i>	FRECUENCIA <i>FREQUENCY</i>	TONOS <i>TONES</i>	ALTA/BAJA INTENSIDAD <i>HIGH/LOW INTENSITY</i>								
GUARDIA URBANA BCN	<table border="1"><tr><td></td><td></td><td></td><td></td></tr><tr><td>1</td><td>2</td><td>3</td><td>4</td></tr></table>					1	2	3	4	550-750 Hz	TWO TONES 68 c/m.	-
1	2	3	4									
DEUTSCHLAND (ALEMANIA)	<table border="1"><tr><td></td><td>2</td><td>3</td><td></td></tr><tr><td>1</td><td></td><td></td><td>4</td></tr></table>		2	3		1			4	432-576 Hz 362-483 Hz	DOPPELTON 40 c/m. DOPPELTON 40 c/m.	STADT / LAND
	2	3										
1			4									
FRANCE AMBULANCE (FRANCIA AMBULANCIA)	<table border="1"><tr><td>1</td><td></td><td>3</td><td></td></tr><tr><td></td><td>2</td><td></td><td>4</td></tr></table>	1		3			2		4	420-516-420 Hz	DEUX TONES 30 c/m.	-
1		3										
	2		4									
FRANCE GENDARMERIE (FRANCIA GENDARMERIA)	<table border="1"><tr><td>1</td><td></td><td></td><td></td></tr><tr><td></td><td>2</td><td>3</td><td>4</td></tr></table>	1					2	3	4	435-735 Hz	DEUX TONES 55 c/m	-
1												
	2	3	4									
FRANCE POLICE (FRANCIA POLICIA)	<table border="1"><tr><td></td><td></td><td>3</td><td></td></tr><tr><td>1</td><td>2</td><td></td><td>4</td></tr></table>			3		1	2		4	435-580 Hz	DEUX TONES 55 c/m.	JOUR / NUIT
		3										
1	2		4									
FRANCE POMPIERS (FRANCIA BOMBEROS)	<table border="1"><tr><td></td><td>2</td><td></td><td></td></tr><tr><td>1</td><td></td><td>3</td><td>4</td></tr></table>		2			1		3	4	435-488 Hz	DEUX TONES 27c/m.	-
	2											
1		3	4									
FRANCE UMH (FRANCIA UMH)	<table border="1"><tr><td>1</td><td>2</td><td></td><td></td></tr><tr><td></td><td></td><td>3</td><td>4</td></tr></table>	1	2					3	4	435-651 Hz	DEUX TONES 55 c/m.	JOUR / NUIT
1	2											
		3	4									
SWITZERLAND (SUIZA)	<table border="1"><tr><td>1</td><td>2</td><td>3</td><td></td></tr><tr><td></td><td></td><td></td><td>4</td></tr></table>	1	2	3					4	450-600 Hz	TWO TONES 40 c/m.	-
1	2	3										
			4									

SCS1000 Día/Noche ref. 2020227

SCS1000 Día/Noche ref. 2020227-BL

- (D)** FUNKTIONSBESCHREIBUNG
- (E)** USO DE LA SIRENA
- (F)** FONCTIONNEMENT DE LA SIRENE
- (GB)** OPERATING INSTRUCTIONS
- (I)** USO DELLA SIRENA

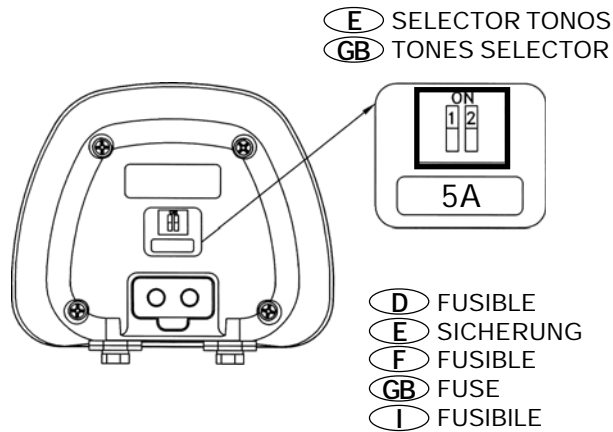

DESCRIPCIÓN DESCRIPTION	SELECTOR TONOS TONES SELECTOR	FRECUENCIA FREQUENCY	TONOS TONES	ALTA/BAJA INTENSIDAD HIGH/LOW INTENSITY				
ESTANDAR	<table border="1" style="text-align: center;"> <tr><td>1</td><td>2</td></tr> <tr><td> </td><td> </td></tr> </table>	1	2			600-1200 Hz	WAIL 12 c/m.	BAJA INTENSIDAD
		1	2					
600-1200 Hz	YELP 180 c/m.							
450-600 Hz	TWO TONES 33 c/m.							
GUARDIA URBANA	<table border="1" style="text-align: center;"> <tr><td> </td><td>2</td></tr> <tr><td>1</td><td> </td></tr> </table>		2	1		550-750 Hz	TWO TONES 68 c/m.	BAJA INTENSIDAD
	2							
1								
TRITONO	<table border="1" style="text-align: center;"> <tr><td>1</td><td> </td></tr> <tr><td> </td><td>2</td></tr> </table>	1			2	420-516-420 Hz	TWO TONES 79 c/m.	BAJA INTENSIDAD
1								
	2							
ITALIA AMBULANCIA 2	<table border="1" style="text-align: center;"> <tr><td> </td><td> </td></tr> <tr><td>1</td><td>2</td></tr> </table>			1	2	600-1200 Hz	WAIL 12 c/m.	BAJA INTENSIDAD
		1	2					
600-1200 Hz	YELP 180 c/m.							
392-660 Hz	TWO TONES 20 c/m.							

BITONE
CANARIAS
DENMARK
FRANCE AMBULANCE
FRANCE GENDARMERIE
FRANCE POMPIERS
IBEROAMERICA/ENGLAND
ITALIA AMBULANZA
ITALIA AMBULANZA 2
ITALIA POLIZIA

NETHERLANDS AMBULANCE
NETHERLANDS POLICE
ÖSTERREICH KRAKENWAGEN
ÖSTERREICH POLIZEI
STANDARD
STANDARD/AIRHORN
SWEDEN
SWITZERLAND
WAIL/YELP/AIRHORN

- (D) ANSCHLUSSPLAN
- (E) ESQUEMA DE CONEXIONADO
- (F) SCHEMA DE CONNEXION
- (GB) WIRING DIAGRAM
- (I) SCHEMA DI CONNESSIONE

- (D) BATTERIE, KABELSATZ, SCHALTER UND SICHERUNG SIND NICHT EINGESCHLOSSEN. ES WERDEN SCHALTER SW-521.
- (E) BATERÍA, CABLEADO, INTERRUPTORES Y FUSIBLES NO INCLUIDOS. SE RECOMIENDA USAR EL INTERRUPTOR SW-521.
- (F) BATTERIE, CABLAGE, INTERRUPTEURS ET FUSIBLES NE SONT PAS INCLUS. ON RECOMMANDE L'EMPLOI DE L'INTERRUPTEUR SW-521.
- (GB) BATTERY, WIRING, SWITCHES AND FUSES NOT INCLUDED. IT IS RECOMMENDED TO USE SW-521 SWITCH.
- (I) BATTERIA, CAVI, INTERRUPTORI E FUSIBILE NON COMPRESI. SI CONSIGLIA DI USARE INTERRUITORI SW-521.

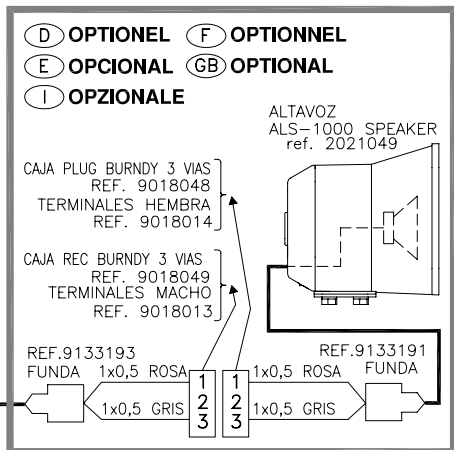
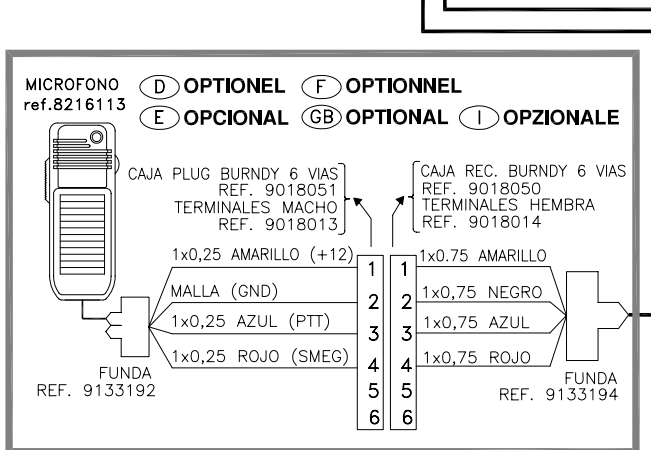
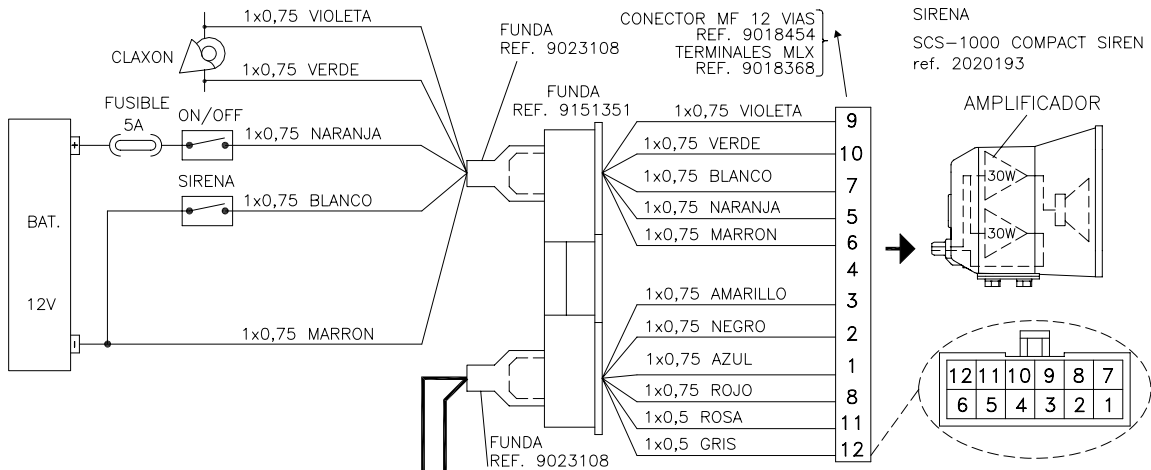

- | | | | | |
|-------------------------|-----------------------|---------------------|-------------------|-------------------|
| (E) | (D) | (F) | (GB) | (I) |
| ALTAVOZ | LAUTSPRECHER | HAUT-PARLEUR | SPEAKER | ALTOPARLANTE |
| AMARILLO | GELB | JAUNE | YELLOW | GIALLO |
| AMPLIFICADOR | VERSTÄRKER | AMPLIFICATUER | AMPLIFIER | AMPLIFICATORE |
| AZUL | BLAU | BLEU | BLUE | AZZURRO |
| BLANCO | WEISS | BLANC | WHITE | BIANCO |
| BATERIA | BATTERIE | BATTERIE | BATTERY | BATERIA |
| CAJA PLUG BURNDY 3 VIAS | 3-WEGE STECKER | RECEP. 3 VOIES | RECEPT. 3 WAYS | RIC. 3 VIE |
| CAJA PLUG BURNDY 6 VIAS | 6-WEGE STECKER | RECEP. 6 VOIES | RECEPT. 6 WAYS | RIC. 6 VIE |
| CAJA REC BURNDY 3 VIAS | 3-WEGE STECKER | PLUG 3 VOIES | PLUG 3 WAYS | PLUG 3 VIE |
| CAJA REC BURNDY 6 VIAS | 6-WEGE STECKER | PLUG 6 VOIES | PLUG 6 WAYS | PLUG 6 VIE |
| CONECTOR MF 12 VIAS | 12-WEGE STECKER | CONNECTEUR 12 VOIES | 12 WAYS CONNECTOR | CONNETTORE 12 VIE |
| CLAXON | HUPENRING | KLAXON | HORN | HORN |
| FUNDA | BEZUG | GAINÉ | COVER | PROTEZIONE |
| FUSIBLE | SICHERUNG | FUSIBLE | FUSE | FUSIBILE |
| GRIS | GRAU | GRIS | GREY | GRIGIO |
| MALLA | KABELABSCHIRMGEFLECHT | MAILLE | WIRE MESH | MAGLIA |
| MARRON | BRAUN | MARRON | BROWN | MARRONE |
| MICROFONO | MIKROPHON | MICROPHONE | MICROPHONE | MICROFONO |
| NARANJA | ORANGE | ORANGE | ORANGE | ARANCIO |
| NEGRO | SCHWARZ | NOIR | BLACK | NERO |
| ROJO | ROT | ROUGE | RED | ROSSO |
| ROSA | ROSA | ROSE | PINK | ROSA |
| SIRENA | SIRENE | SIRENE | SIREN | SIRENA |
| TERMINALES HEMBRA | WEIBLICHES GEGENSTUCK | BORNES FEMELLE | FEMALE TERMINAL | TERMINALE FEMMINA |
| TERMINALES MACHO | MANNLICHES GEGENSTUCK | BORNES MALE | MALE TERMINAL | TERMINALE MASCHIO |
| TERMINALES MLX | MLX GEGENSTUCK | BORNES MLX | MLX TERMINAL | TERMINALE MLX |

- (D)** BATTERIE, KABELSATZ, SCHALTER UND SICHERUNG SIND NICHT EINGESCHLOSSEN. ES WERDEN SCHALTER SW-521.
(E) BATERIA, CABLEADO, INTERRUPTORES Y FUSIBLES NO INCLUIDOS. SE RECOMIENDA USAR EL INTERRUPTOR SW-521.
(F) BATTERIE, CABLAGE, INTERRUPTEURS ET FUSIBLES NE SONT PAS INCLUS. ON RECOMMANDE L'EMPLOI DE L'INTERRUPTEUR SW-521.
(GB) BATTERY, WIRING, SWITCHES AND FUSES NOT INCLUDED. IT IS RECOMMENDED TO USE SW-521 SWITCH.
(I) BATTERIA, CAVI, INTERRUTTORTI E FUSIBILE NON COMPRESI. SI CONSIGLIA DI USARE INTERRUTORI SW-521.

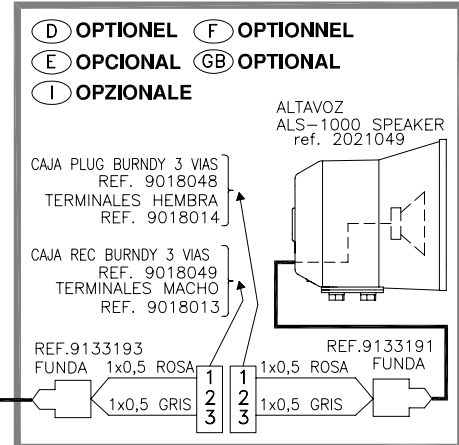
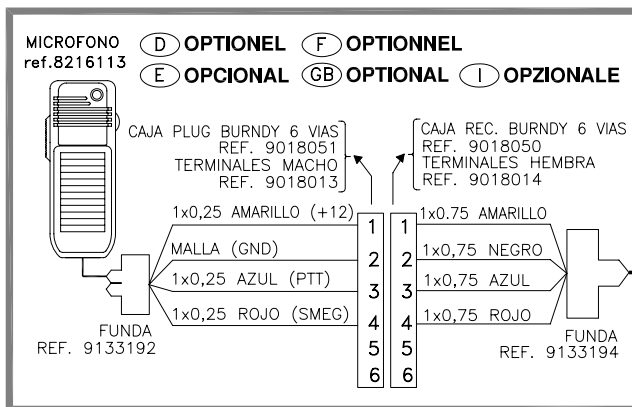
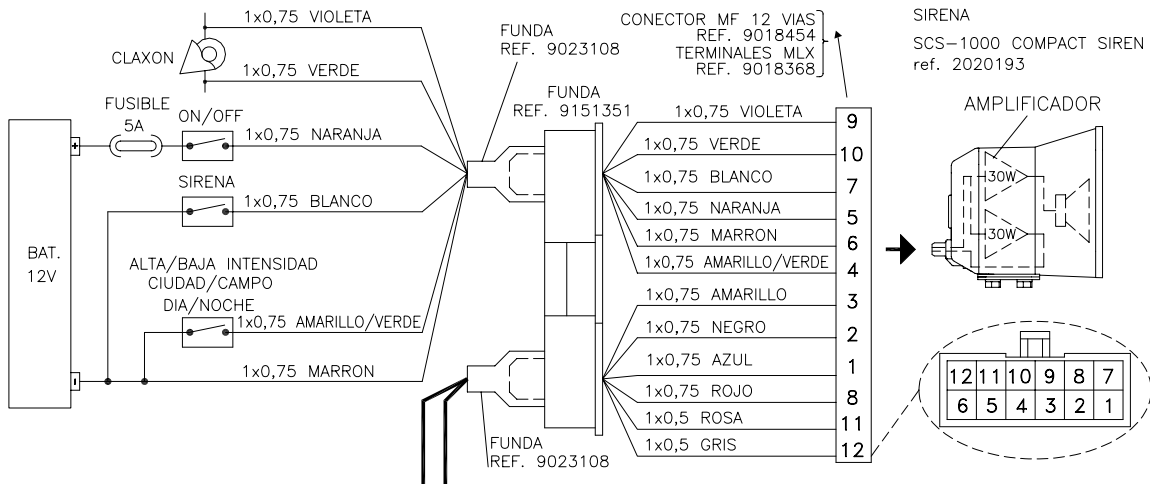

(E)	(D)	(F)	(GB)	(I)
ALTA/BAJA INTENSIDAD	STARKE/SCHWACH INTENSITÄT	MAXIMUM/FAIBLE INTENSITÉ	HIGH/LOW INTENSITY	ALTA/BASSA INTENSITA
ALTAVOZ	LAUTSPRECHER	HAUT-PARLEUR	SPEAKER	ALTOPARLANTE
AMARILLO	GELB	JAUNE	YELLOW	GIALLO
AMARILLO/VERDE	GELB/GRÜN	JAUNE/VERT	YELLOW/GREEN	GIALLO/VERDE
AMPLIFICADOR	VERSTÄRKER	AMPLIFICATUER	AMPLIFIER	AMPLIFICATORE
AZUL	BLAU	BLEU	BLUE	AZZURRO
BLANCO	WEISS	BLANC	WHITE	BIANCO
BATERIA	BATTERIE	BATTERIE	BATTERY	BATERIA
CAJA PLUG BURNDY 3 VIAS	3-WEGE STECKER	RECEP. 3 VOIES	RECEPT. 3 WAYS	RIC. 3 VIE
CAJA PLUG BURNDY 6 VIAS	6-WEGE STECKER	RECEP. 6 VOIES	RECEPT. 6 WAYS	RIC. 6 VIE
CAJA REC BURNDY 3 VIAS	3-WEGE STECKER	PLUG 3 VOIES	PLUG 3 WAYS	PLUG 3 VIE
CAJA REC BURNDY 6 VIAS	6-WEGE STECKER	PLUG 6 VOIES	PLUG 6 WAYS	PLUG 6 VIE
CIUDAD/CAMPO	STADT/LAND	CITÉ/CAMPAGNE	CITY/COUNTRY	CITTÀ/CAMPAGNA
CONECTOR MF 12 VIAS	12-WEGE STECKER	CONNECTEUR 12 VOIES	12 WAYS CONNECTOR	CONNETTORE 12 VIE
CLAXON	HUPENRING	KLAXON	HORN	HORN
DIA/NOCHE	TAG/NACHT	JOUR/NUIT	DAY/NIGHT	GIORNO/NOTTE
FUNDA	BEZUG	GAINÉ	COVER	PROTEZIONE
FUSIBLE	SICHERUNG	FUSIBLE	FUSE	FUSIBILE
GRIS	GRAU	GRIS	GREY	GRIGIO
MALLA	KABELABSCHIRMGEFLECHT	MAILLE	WIRE MESH	MAGLIA
MARRON	BRAUN	MARRON	BROWN	MARRONE
MICROFONO	MIKROPHON	MICROPHONE	MICROPHONE	MICROFONO
NARANJA	ORANGE	ORANGE	ORANGE	ARANCIO
NEGRO	SCHWARZ	NOIR	BLACK	NERO
ROJO	ROT	ROUGE	RED	ROSSO
ROSA	ROSA	ROSE	PINK	ROSA
SIRENA	SIRENE	SIRENE	SIREN	SIRENA
TERMINALES HEMBRA	WEIBLICHES GEGENSTUCK	BORNES FEMELLE	FEMALE TERMINAL	TERMINALE FEMMINA
TERMINALES MACHO	MÄNNLICHES GEGENSTUCK	BORNES MALE	MALE TERMINAL	TERMINALE MASCHIO
TERMINALES MLX	MLX GEGENSTUCK	BORNES MLX	MLX TERMINAL	TERMINALE MLX

DIA/NOCHE / ESTANDAR

D FUNKTIONSBESCHREIBUNG

E USO DE LA SIRENA

F FONCTIONNEMENT DE LA SIRENE

GB OPERATING INSTRUCTIONS

I USO DELLA SIRENA

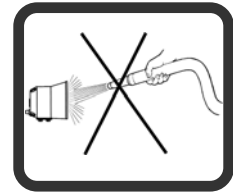

<p>1</p>	<p>2</p> <p>OFF</p> <p>OFF</p>	<p>3</p>
----------	--------------------------------	----------

<p>1</p>	<p>2</p> <p>OFF</p> <p>ON</p>	<p>3</p>
<p>4</p>		<p>5</p>

<p>1</p>	<p>2</p> <p>ON</p>	<p>3</p>
----------	--------------------	----------

PTT

VOL

DIA/NOCHE / GUARDIA URBANA

DIA/NOCHE / TRITONO

(D) FUNKTIONSBESCHREIBUNG

(E) USO DE LA SIRENA

(F) FONCTIONNEMENT DE LA SIRENE

(GB) OPERATING INSTRUCTIONS

(I) USO DELLA SIRENA

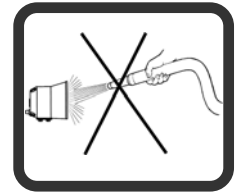

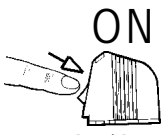
1  ON
ON/OFF

2 OFF
BAJA INTENSIDAD
OFF
SIR

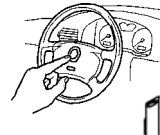
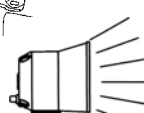
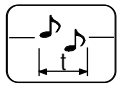
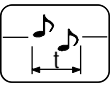
3    TWO TONES  TWO TONES

1  ON
ON/OFF

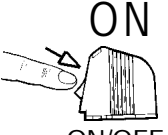

2 OFF
BAJA INTENSIDAD
ON
SIR

  TWO TONES

1  ON
ON/OFF

2 ON
BAJA INTENSIDAD

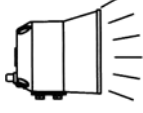
3 ON
SIR

  TWO TONES

PTT

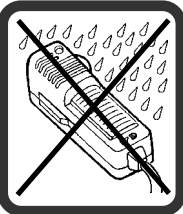

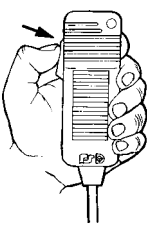
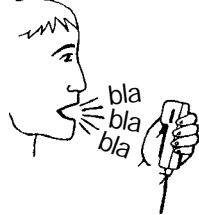
  bla
bla
bla

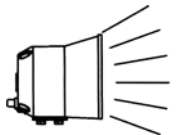
 bla
bla
bla

VOL

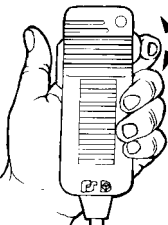
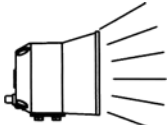
  bla
bla
bla

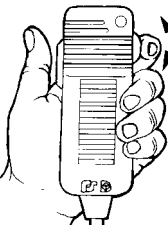
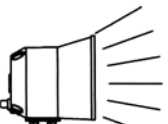
  bla
bla
bla

DIA/NOCHE / ITALIA AMBULANCIA 2

D FUNKTIONSBESCHREIBUNG

E USO DE LA SIRENA

F FONCTIONNEMENT DE LA SIRENE

GB OPERATING INSTRUCTIONS

I USO DELLA SIRENA

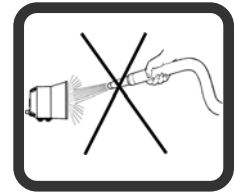

<p>1</p>	<p>2</p> <p>OFF</p> <p>BAJA INTENSIDAD</p> <p>OFF</p> <p>SIR</p>	<p>3</p>
----------	--	----------

<p>1</p>	<p>2</p> <p>OFF</p> <p>BAJA INTENSIDAD</p> <p>ON</p>	<p>3</p>
<p>4</p>		<p>5</p>

<p>1</p>	<p>2</p> <p>ON</p> <p>BAJA INTENSIDAD</p>	<p>3</p>
----------	---	----------

PTT

VOL

STANDARD

D FUNKTIONSBESCHREIBUNG

E USO DE LA SIRENA

F FONCTIONNEMENT DE LA SIRENE

GB OPERATING INSTRUCTIONS

I USO DELLA SIRENA

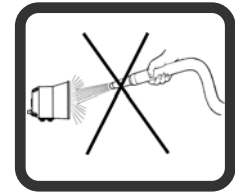

<p>1</p> <p>ON/OFF</p>	<p>2</p> <p>SIR</p>	<p>3</p> <p>WAIL</p>
------------------------	---------------------	----------------------

<p>1</p> <p>ON/OFF</p>	<p>2</p> <p>SIR</p> <p>WAIL</p>	<p>3</p> <p>YELP</p>
------------------------	---------------------------------	----------------------

<p>4</p> <p>TWO TONES</p>	<p>5</p> <p>WAIL</p>
---------------------------	----------------------

PTT

VOL

STANDARD/AIRHORN

D FUNKTIONSBESCHREIBUNG

E USO DE LA SIRENA

F FONCTIONNEMENT DE LA SIRENE

GB OPERATING INSTRUCTIONS

I USO DELLA SIRENA

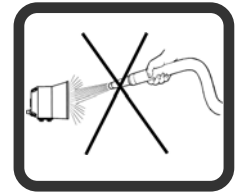

<p>1</p> <p>ON ON/OFF</p>	<p>2</p> <p>OFF SIR</p>	<p>3</p> <p>AIRHORN</p>
-------------------------------	-----------------------------	-------------------------

<p>1</p> <p>ON ON/OFF</p>	<p>2</p> <p>ON SIR</p> <p>WAIL</p>	<p>3</p> <p>YELP</p>
-------------------------------	--	----------------------

<p>4</p> <p>TWO TONES</p>	<p>5</p> <p>WAIL</p>
---------------------------	----------------------

PTT

bla
bla
bla

bla
bla
bla

VOL

bla
bla
bla

bla
bla
bla

WAIL/YELP/AIRHORN

D FUNKTIONSBESCHREIBUNG

E USO DE LA SIRENA

F FONCTIONNEMENT DE LA SIRENE

GB OPERATING INSTRUCTIONS

I USO DELLA SIRENA

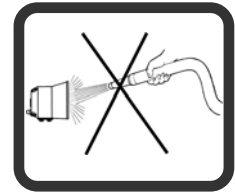

1

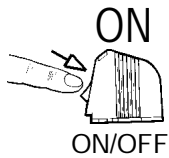

2



3



1

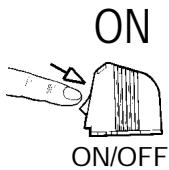

2

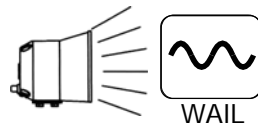
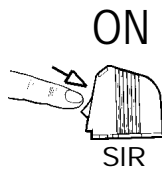

3

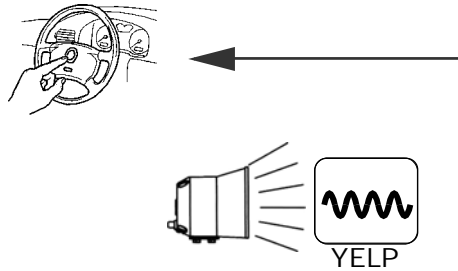

4

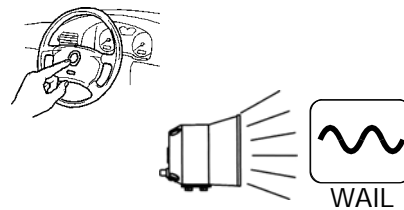

PTT

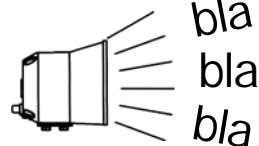
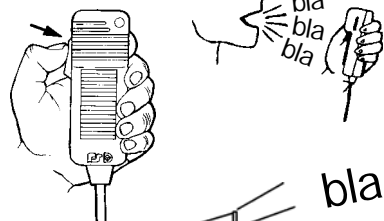
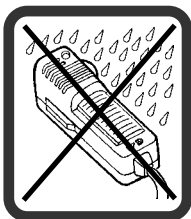

VOL

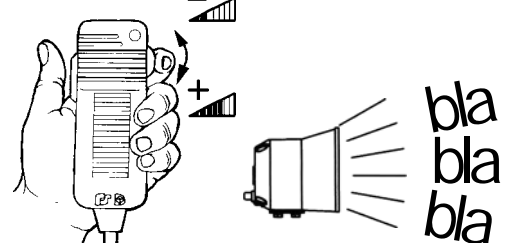

IBEROAMÉRICA ENGLAND

D FUNKTIONSBESCHREIBUNG

E USO DE LA SIRENA

F FONCTIONNEMENT DE LA SIRENE

GB OPERATING INSTRUCTIONS

I USO DELLA SIRENA

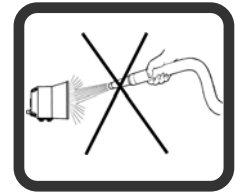

1

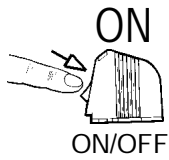

2



3

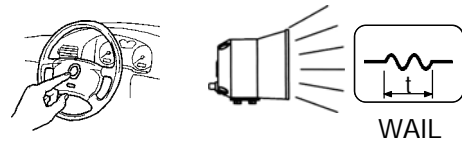

1

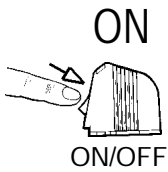

2

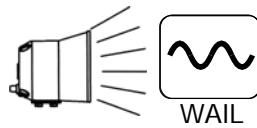
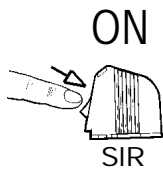

3

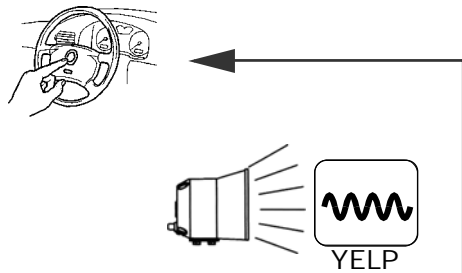

4

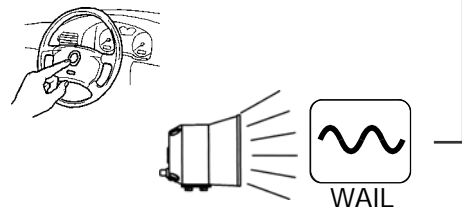

PTT

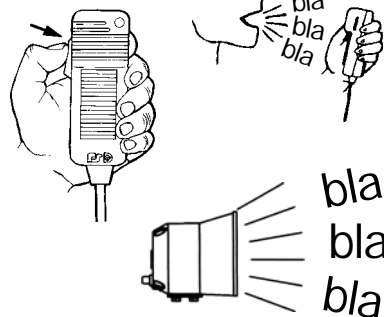

VOL

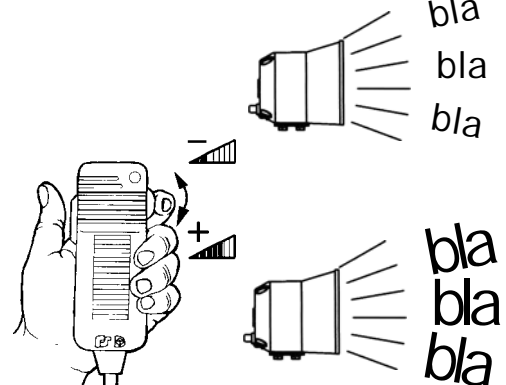

DENMARK

D FUNKTIONSBESCHREIBUNG

E USO DE LA SIRENA

F FONCTIONNEMENT DE LA SIRENE

GB OPERATING INSTRUCTIONS

I USO DELLA SIRENA

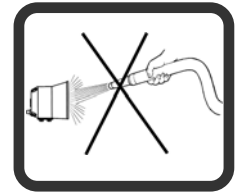

1

2

3

1

2

3

4

PTT

VOL

SWEDEN

D FUNKTIONSBESCHREIBUNG

E USO DE LA SIRENA

F FONCTIONNEMENT DE LA SIRENE

GB OPERATING INSTRUCTIONS

I USO DELLA SIRENA

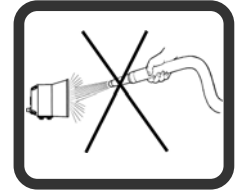

1

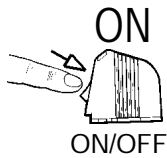

2



3

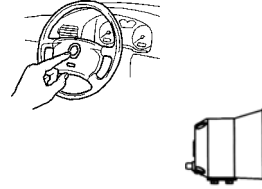

1

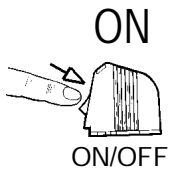

2

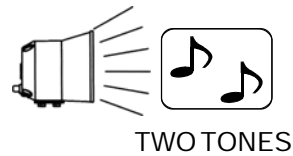
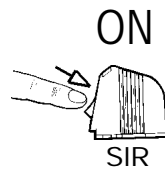

3

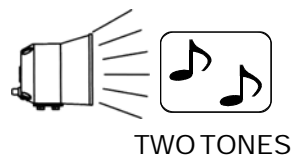
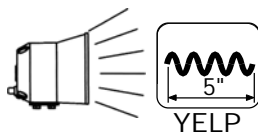

PTT

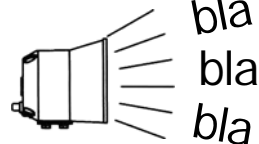
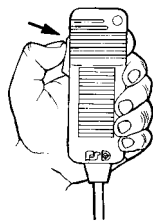

VOL

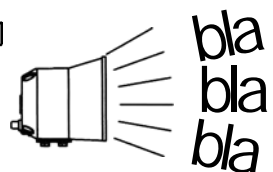
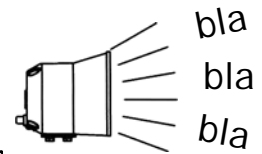
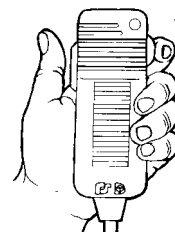

BITONE
CANARIAS
FRANCE AMBULANCE
FRANCE GENDARMERIE
FRANCE POMPIERS
GUARDIA URBANA BCN

NETHERLANDS AMBULANCE
ÖSTERREICH POLIZEI
ÖSTERREICH KRANKENWAGEN
SWITZERLAND
ITALIA AMBULANZA
ITALIA POLIZIA

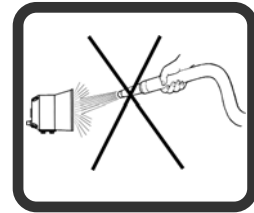

(D) FUNKTIONSBESCHREIBUNG

(E) USO DE LA SIRENA

(F) FONCTIONNEMENT DE LA SIRENE

(GB) OPERATING INSTRUCTIONS

(I) USO DELLA SIRENA

1

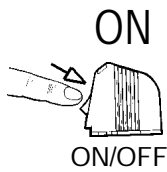

2



3

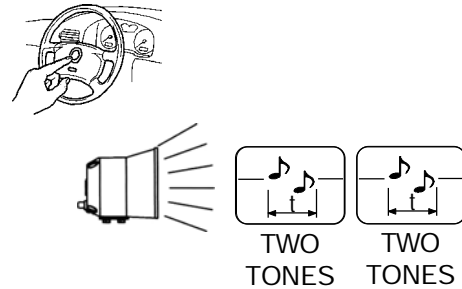

1

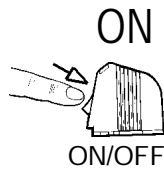

2

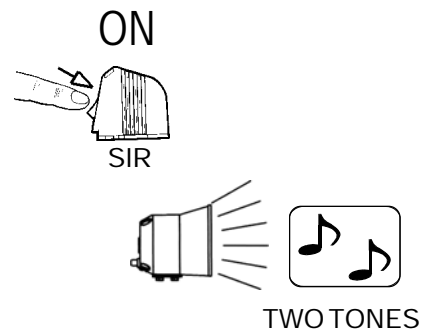

PTT

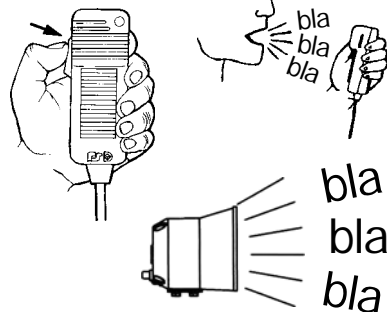

VOL

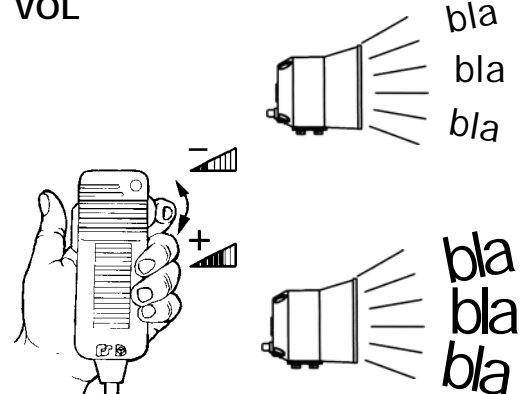

NETHERLANDS POLICE

D FUNKTIONSBESCHREIBUNG

E USO DE LA SIRENA

F FONCTIONNEMENT DE LA SIRENE

GB OPERATING INSTRUCTIONS

I USO DELLA SIRENA

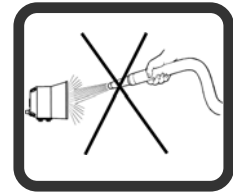

<p>1</p> <p style="text-align: center;">ON</p> <p style="text-align: center;">ON/OFF</p>	<p>2</p> <p style="text-align: center;">OFF</p> <p style="text-align: center;">SIR</p>	<p>3</p> <p style="text-align: center;">(f: 375-500 Hz 66 c/m.)</p> <p style="text-align: center;">GB TWO TONES</p>
---	---	--

<p>1</p> <p style="text-align: center;">ON</p> <p style="text-align: center;">ON/OFF</p>	<p>2</p> <p style="text-align: center;">ON</p> <p style="text-align: center;">SIR</p> <p style="text-align: center;">(f: 375-500 Hz 33 c/m.)</p> <p style="text-align: center;">GB TWO TONES</p>
---	--

3

(f: 375-500 Hz 66 c/m.)

GB TWO TONES

→

(f: 375-500 Hz 33 c/m.)

GB TWO TONES

PTT

VOL

DEUTSCHLAND
FRANCE POLICE
FRANCE UMH

D FUNKTIONSBESCHREIBUNG

E USO DE LA SIRENA

F FONCTIONNEMENT DE LA SIRENE

GB OPERATING INSTRUCTIONS

I USO DELLA SIRENA

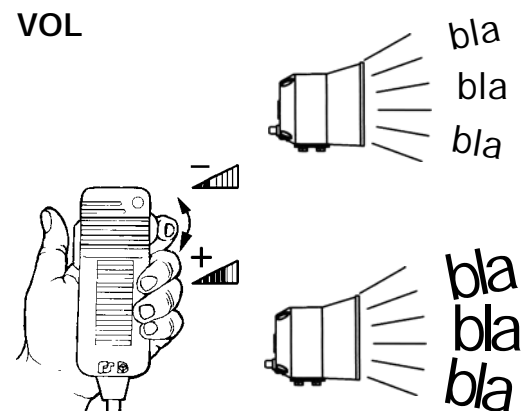
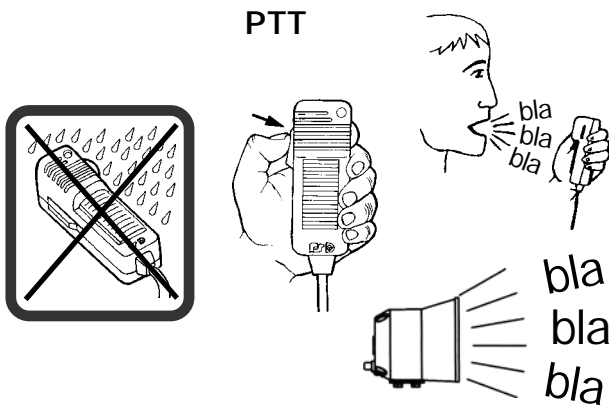
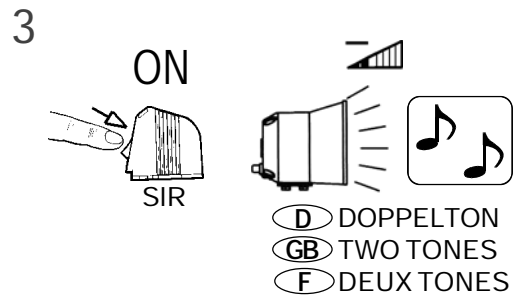
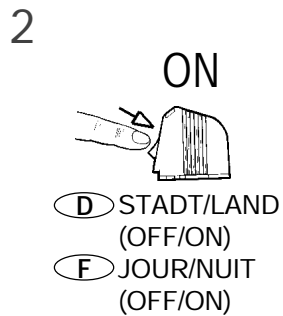
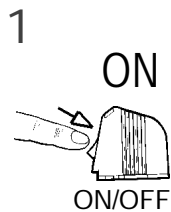
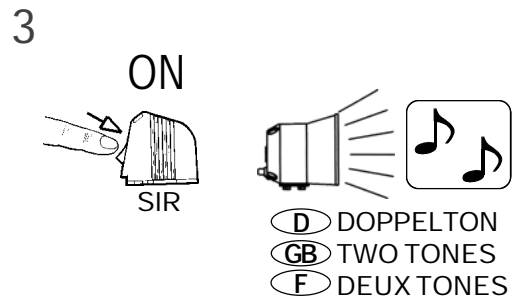
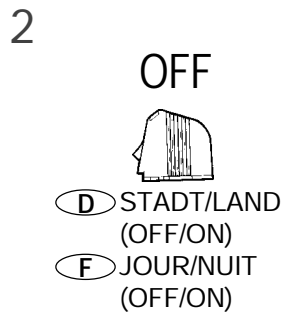
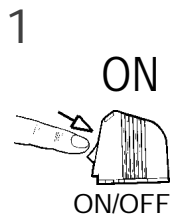
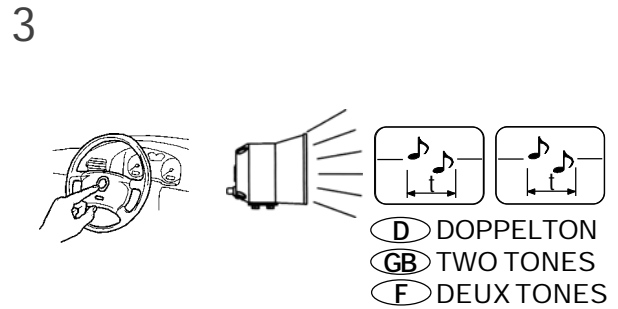
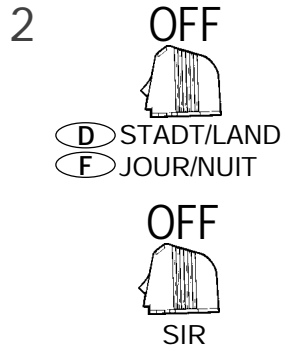
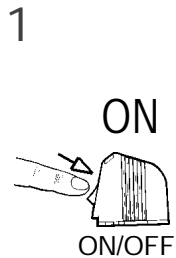
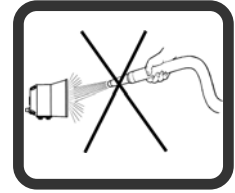

ITALIA AMBULANZA 2

D FUNKTIONSBESCHREIBUNG

E USO DE LA SIRENA

F FONCTIONNEMENT DE LA SIRENE

GB OPERATING INSTRUCTIONS

I USO DELLA SIRENA

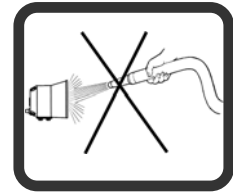

<p>1</p> <p>ON/OFF</p>	<p>2</p> <p>SIR</p>	<p>3</p> <p>WAIL</p>
------------------------	---------------------	----------------------

<p>1</p> <p>ON/OFF</p>	<p>2</p> <p>SIR</p>	<p>3</p> <p>TWO TONES</p>
------------------------	---------------------	---------------------------

<p>4</p> <p>WAIL</p>	<p>5</p> <p>YELP</p>
----------------------	----------------------

PTT

bla
bla
bla

bla
bla
bla

VOL

bla
bla
bla

bla
bla
bla

SCS1000 ref. 2020200
 SCS1000-FG ref. 2020193
 SCS1000N ref. 2020207
 SCS1000N-FG ref. 2020217
 SCS1000 Día/Noche ref. 2020227

SCS1000 ref. 2020200-BL
 SCS1000-FG ref. 2020193-BL
 SCS1000N ref. 2020207-BL
 SCS1000N-FG ref. 2020217-BL
 SCS1000 Día/Noche ref. 2020227-BL

D ERSATZTEILE **E** RECAMBIOS **F** PIECES DE RECHANGE **GB** SPARE PARTS **I** RICAMBI

1x ref. 8299372
 (ref. 2020200 / 2020193 / 2020227)
 1x ref. 8299372-BL
 (ref. 2020200-BL / 2020193-BL / 2020227-BL)
 1x ref. 8299413
 (ref. 2020207 / 2020217)
 1x ref. 8299413-BL
 (ref. 2020207-BL / 2020217-BL)

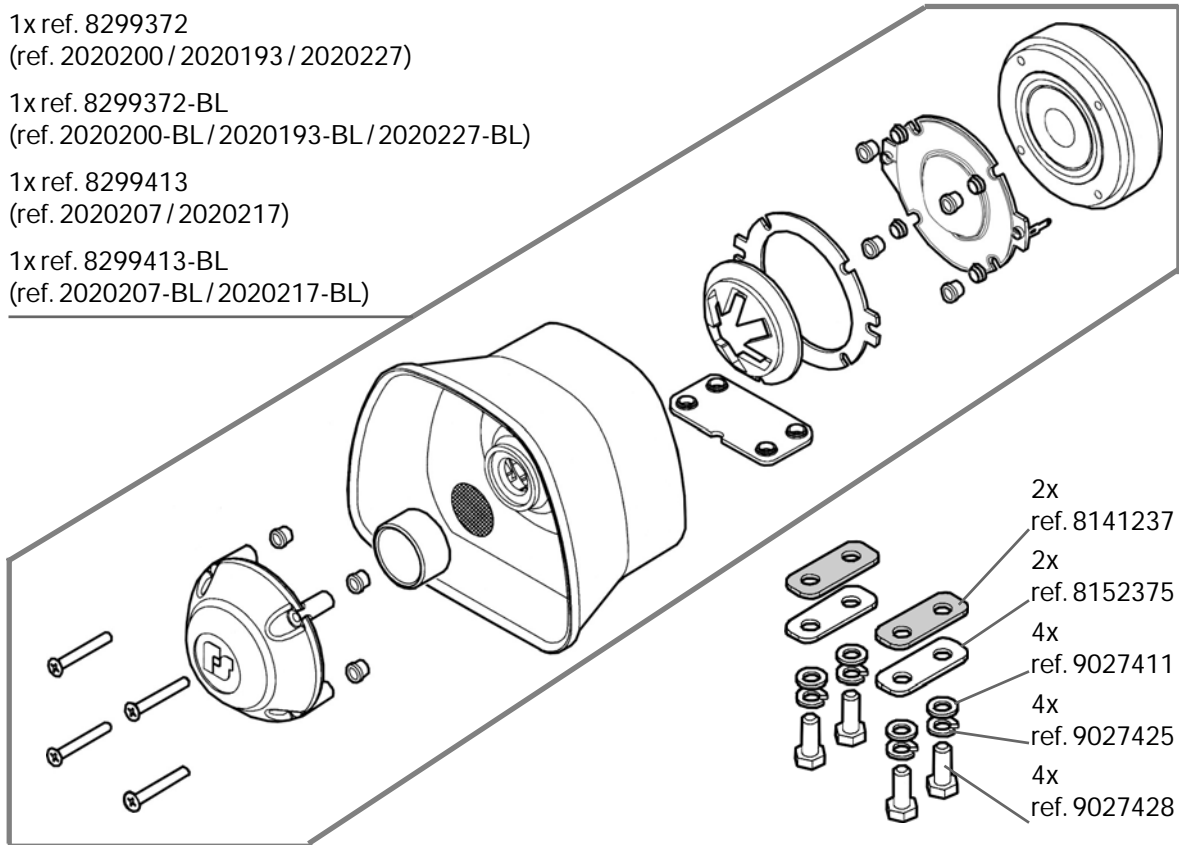

1x ref. 8299370
 (ref. 2020200 / 2020193 / 2020227 / 2020207 / 2020217)
 1x ref. 8299370-BL
 (ref. 2020200-BL / 2020193-BL / 2020227-BL / 2020207-BL / 2020217BL)

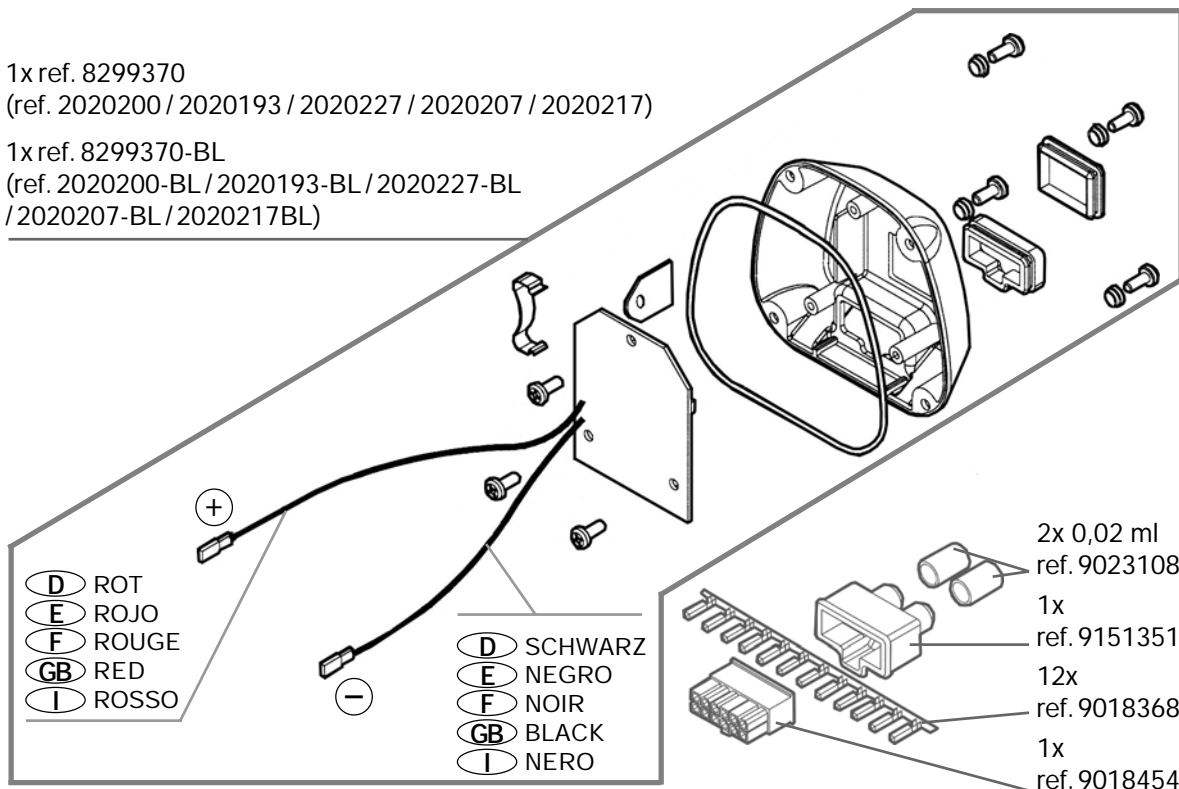

D ROT
E ROJO
F ROUGE
GB RED
I ROSSO

D SCHWARZ
E NEGRO
F NOIR
GB BLACK
I NERO

ALS1000 ref. 2021049
 ALS1000N ref. 2021050
 ALS1000 ref. 2021049-BL
 ALS1000N ref. 2021050-BL

- (D)** ERSATZEILE
- (E)** RECAMBIOS
- (F)** PIECES DE RECHANGE
- (GB)** SPARE PARTS
- (I)** RICAMBI

1x ref. 8299372
 (ref. 2021049)
 1x ref. 8299372-BL
 (ref. 2021049-BL)
 1x ref. 8299413
 (ref. 2021050)
 1x ref. 8299413-BL
 (ref. 2021050-BL)

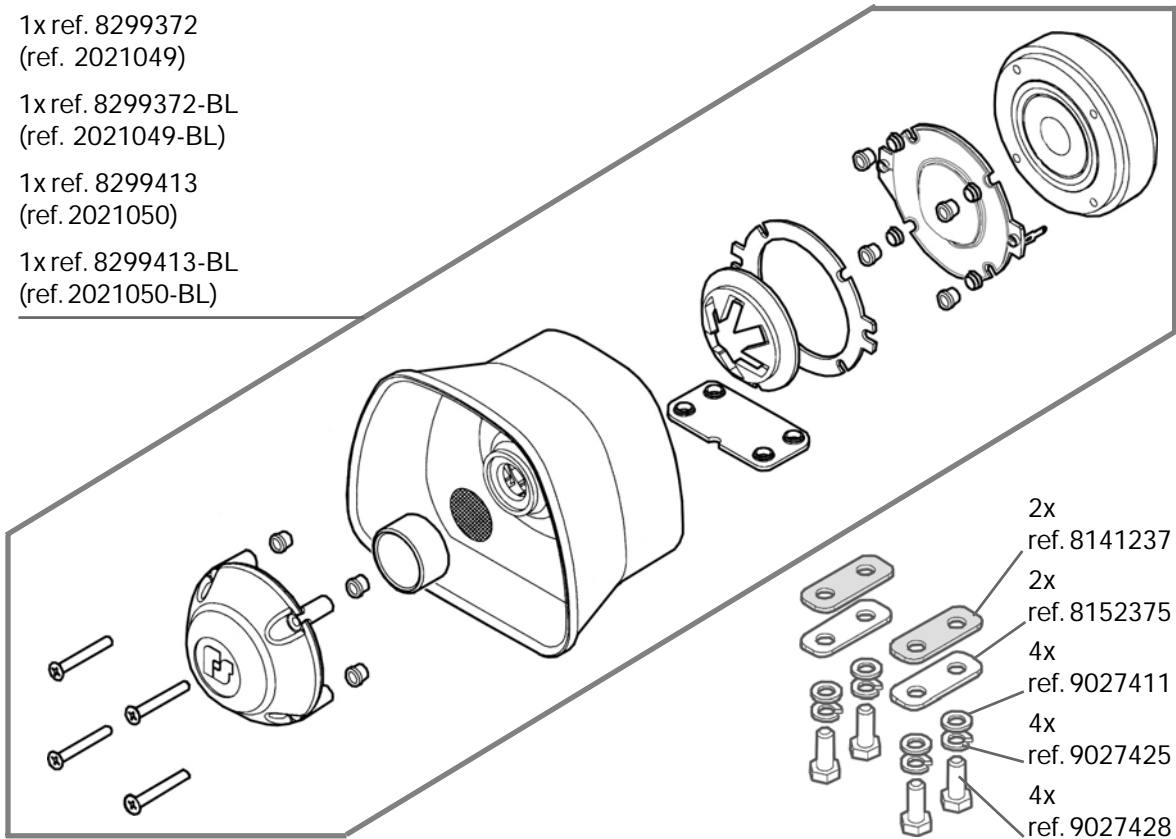

1x ref. 8299369
 (ref. 2021049 / 2021050)
 1x ref. 8299369-BL
 (ref. 2021049-BL / 2021050-BL)

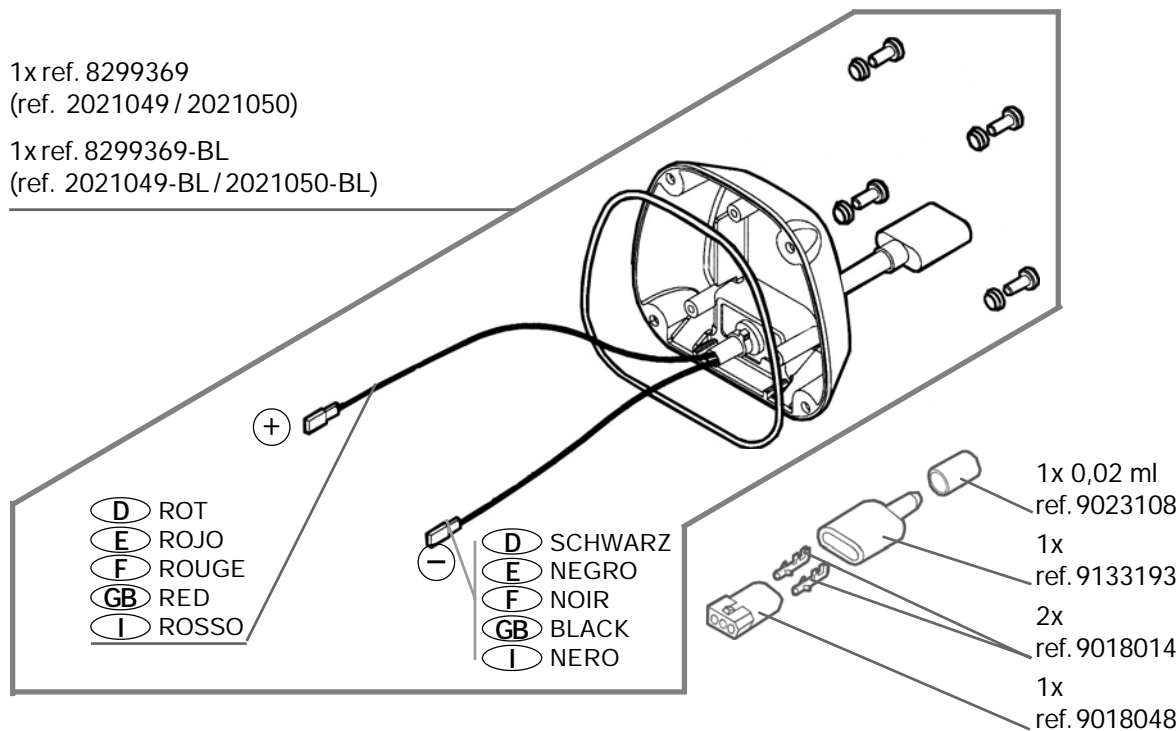

- (D)** ROT
- (E)** ROJO
- (F)** ROUGE
- (GB)** RED
- (I)** ROSSO

- (D)** SCHWARZ
- (E)** NEGRO
- (F)** NOIR
- (GB)** BLACK
- (I)** NERO

- (D)** OPCIONALES ZUBEHÖR
- (E)** ACCESORIOS OPCIONALES
- (F)** ACCESSOIRES COMPLÉMENTAIRES

- (GB)** OPTIONAL ACCESSORIES
- (I)** ACCESSORI EVENTUALI

SCS1000-PA

1x
ref.8216113

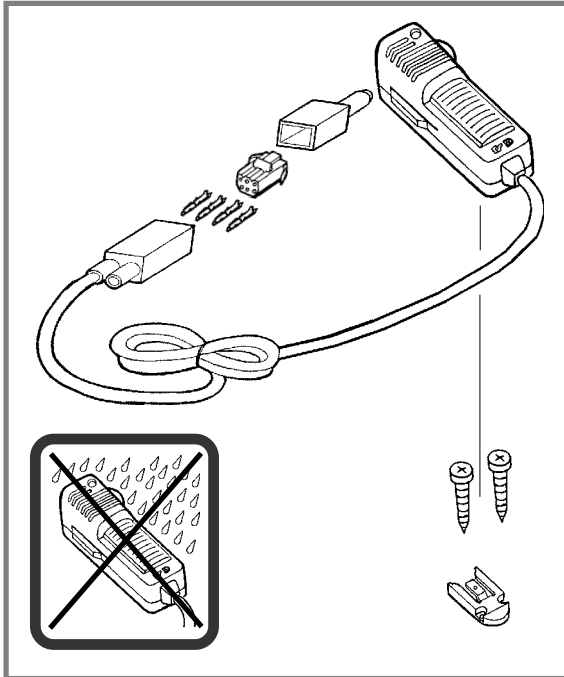

SW-521

3x
ref.8216090

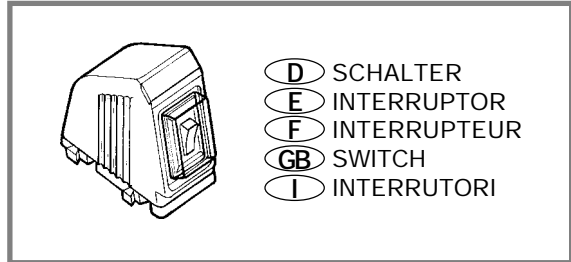

1x
ref.9015100

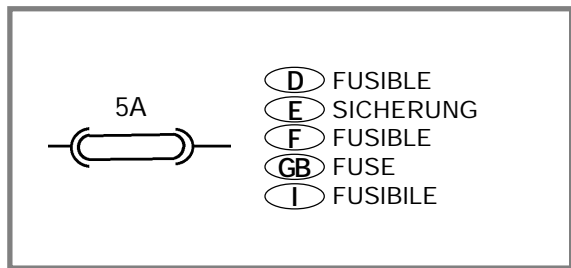

ALS-1000 Speaker

1x
ref.2021049

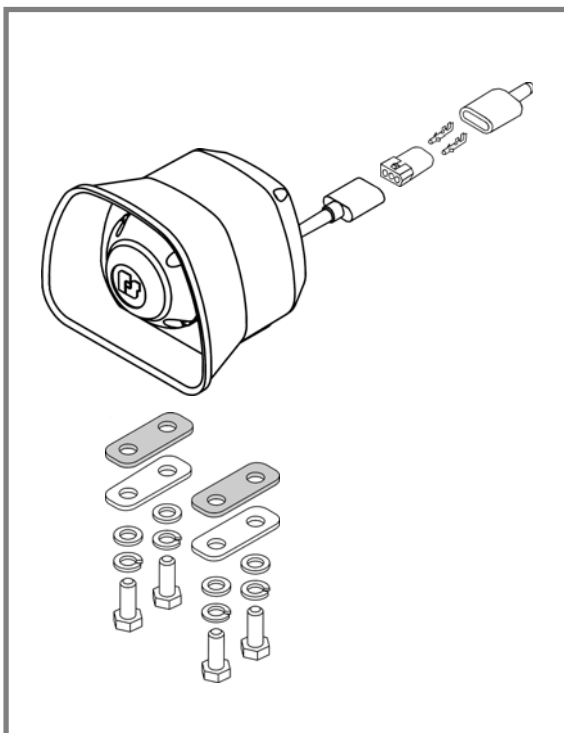

SCS1000-BLOCK

1x
ref.8299306

